



High Performance Building

Dow Performance Silicones

DOWSIL™ Brand Silicone Pavement Sealants

Installation Guide



Table of Contents

Preface	4
DOWSIL™ Silicone Pavement Sealants	5
What Are they?	5
Where to Use Them	5
Other Applications	6
Important Considerations	6
Field Adhesion Test	7
Figure 1 – Standard Field Adhesion Hand Pull Test.....	8
How To Use DOWSIL™ Silicone Pavement Sealants	9
Cure Characteristics	9
Joint Design	9
Joint Width.....	10
Figure 2 – Joint Design Considerations: DOWSIL™ 888 Silicone Joint Sealant	11
Figure 3 – Joint Design Considerations: DOWSIL™ 890-SL Silicone Joint Sealant	12
Joint Depth	13
Table 1 – Recommended Joint Depth.....	13
Joint Preparation.....	13
Backer Rod Selection	14
Sealant and Backer Rod Placement Depths.....	14
Sealing New Concrete Pavement	15

Resealing Old Concrete Pavement	18
Table 2 – Theoretical Estimating Requirements.....	19
Table 3 – Metric Estimating Equivalents	19
Full Depth Asphalt Pavements.....	20
Sealing New Asphalt Pavements	20
Resealing Old Asphalt Pavements	21
Asphalt Overlays	22
Sealing Joints in New Asphalt Overlays.....	22
Sealing Concrete/Asphalt Shoulder Joints	22
Backer Material Installation	23
Figure 4 – Backer Rod Installation Tools.....	24
Sealant Installation	24
Installation Equipment.....	26
Figure 5 – Extrusion Pump	26
Table 4 – Manufacturers of Power Installation Equipment	28
Manual Installation Equipment	29
Specification Information	29
Figure 6 – Installation	30
Questions and Answers.....	32
Key Word Index	35

Preface

Highway and airport joints call for tough sealants that can withstand horizontal and vertical movement, have good weatherability and are easy to install with a short downtime and long service life.

DOWSIL™ 888 Silicone Joint Sealant and DOWSIL™ 890-SL Silicone Joint Sealant are one-part silicone formulations that can be extruded from -20°F to 120°F. In addition, DOWSIL™ 890-SL Silicone Joint Sealant can be used on asphalt. These sealants cure upon exposure to moisture in the air to form a flexible, low- to ultra-low-modulus, high-elongation silicone rubber seal. These sealants will collectively be referred to as DOWSIL™ silicone pavement sealants throughout this guide.

DOWSIL™ silicone pavement sealants are capable of withstanding extension of 100 percent and compression of 50 percent of the original joint width. They have excellent recovery, which makes them ideal for use in joints that experience a high degree of movement. DOWSIL™ 890-SL Silicone Joint Sealant is an ultra-low-modulus sealant that can be used to seal joints in asphalt pavements because it places very little stress on the asphalt joint face. Asphalt paving materials have low tensile strengths and require a sealant that places very little stress on the asphalt itself while keeping the joint sealed.

To fully utilize these capabilities, the sealant must be properly installed in properly designed joints. This guide provides the correct installation procedures, which begin with good joint design and preparation. The pamphlet also covers backer rod installation, giving a list of installation equipment and manufacturers of recommended equipment, as well as the most frequently asked questions and answers. In addition to this guide, installation videos are also available and viewing is suggested.

DOWSIL™ 888 Silicone Joint Sealant

www.youtube.com/watch?v=pZazfD0ObDw

DOWSIL™ 890-SL Silicone Joint Sealant

www.youtube.com/watch?v=Dqty3sONzkU

DOWSIL™ Silicone Pavement Sealants

What are they?

DOWSIL™ silicone pavement sealants are members of the same family and based on similar technologies. DOWSIL™ 888 Silicone Joint Sealant is a one-part, non-sag silicone formulation that can be extruded from -20°F to 120°F. It requires tooling and cures when exposed to atmospheric moisture to form a durable, flexible, low-modulus, high-elongation silicone rubber joint sealant for use on Portland Cement Concrete (PCC). Primer is not required on most applications. During application, no heating or cooling of the sealant is required. It retains its gunnability and can be pumped at low temperatures.

DOWSIL™ 890-SL Silicone Joint Sealant is a one-part, self-leveling silicone sealant that can be extruded from -20°F to 120°F. It cures when exposed to atmospheric moisture to form a durable, flexible, ultra-low-modulus, high-elongation silicone rubber joint seal for use on asphalt and/or Portland Cement Concrete. Primer is not required on most applications. During application, no heating or cooling of the sealant is required. It retains its gunnability and can be pumped at low temperatures.

Where to Use Them

DOWSIL™ 888 Silicone Joint Sealant is ideal for use in concrete-to-concrete joints (PCC) that experience a high degree of movement, such as transverse pavement expansion and contraction joints in highways, airports and other pavements. It withstands extension of 100 percent and compression of 50 percent of original joint width and has excellent recovery. It can be used in transverse, longitudinal, centerline and shoulder joints. Its non-slump characteristic makes it an excellent choice for vertical joints in curbs. It is often used in remedial work where joint widths may not be uniform.

DOWSIL™ 890-SL Silicone Joint Sealant is ideal for use in asphalt-to-concrete and concrete-to-concrete joints that experience a high degree of movement, such as transverse pavement expansion and contraction joints in highways, airports and other pavements. It can be used in longitudinal, centerline and shoulder joints.

It is also ideal for use in sealing concrete-to-asphalt joints such as shoulder joints. Its self-leveling characteristic makes it an excellent choice for horizontal joints and for joints on moderate slopes. It can also be used in remedial work where joint widths may not be uniform.

Some joints, such as bridge joints, may experience a great deal of movement shortly after sealant installation. DOWSIL™ 902 RCS Joint Sealant is ideal for those types of applications due to this product's rapid cure characteristics.

Other Applications

Contact your Dow representative for more information on the applications listed below or others:

- Airports
- Fast Track Pavements
- Bridge Joints
- Pavements on Grades
- Steel/Armor Joints
- Short-term Exposure Fuel Resistance (See Dow literature form number 62-207)

Important Considerations

Joint faces must be clean, dry and frost-free when the sealant is installed. Joints must be free of standing water, and under no circumstances should sealing take place during inclement weather.

Joint Cleanliness – A clean joint should have no visible signs of residual sealant or debris on the joint face and leave no residual cement powder or dust on your fingers after rubbing the joint face.

Pavement Drainage – DOWSIL™ silicone pavement sealants are not recommended for conditions where continuous water or moisture exposure is expected. Sources of subsurface water infiltration include a high water table, shallow or poor drainage ditches or improperly designed or maintained

subsurface drainage systems. All potential applications should be reviewed to ensure the pavement has positive drainage. The correct application of a primer has been shown to enhance performance of the sealant in these situations; contact your Dow representative for more details.

Dew Point – This is the temperature at which the air is saturated with moisture vapor and liquid water (dew) begins to form. Do not install sealant when the temperature is at or below the dew point. Additionally, conditions should be closely monitored if temperatures are approaching the dew point.

Inclement Weather – If rain or other inclement weather occurs during joint preparation or sealing, all operations should cease and sufficient time must be allowed so the joints are dry prior to starting or continuing the sealing operation. Joints that were cleaned but left open during inclement weather may need to be cleaned again prior to sealing due to the potential for contamination from run-off water.

Confined Spaces – DOWSIL™ silicone pavement sealants are not recommended for use in totally confined joints where the sealant is not exposed to atmospheric moisture during cure.

Field Adhesion Test

Prior to work of any kind pertaining to joint sealing, the joint sealing contractor, the owner or owner's representative and the Dow representative, should meet and discuss methods of installation and install a test section. A field adhesion test must be performed on the test section as outlined in Dow's field adhesion test procedure to confirm adhesion under site conditions. Field adhesion tests should also be performed and documented as the project proceeds.

The field adhesion test is a simple screening procedure that may help detect application problems, such as improper cleaning, use of improper primer, poor primer application or improper joint configuration. The sealant typically needs to cure 14 to 21 days prior to performing field adhesion tests.

1. Make a knife cut perpendicular to the joint from one side of the joint to the other.
2. Make two parallel cuts approximately 2" long, along each side of the joint.
3. Place a 1" mark on the sealant tab as shown in Figure 1.
4. Grasp the 2" piece of sealant firmly just beyond the 1" mark and pull at a 90° angle. Hold a ruler alongside the sealant.
5. If the 1" mark on the sealant can be pulled to the 5 1/2" mark on the ruler (total pull of 4 1/2" or 450% elongation) and held with no failure of sealant, the sealant should perform in a joint designed for +100/-50% movement.

Figure 1 – Standard Field Adhesion Hand Pull Test

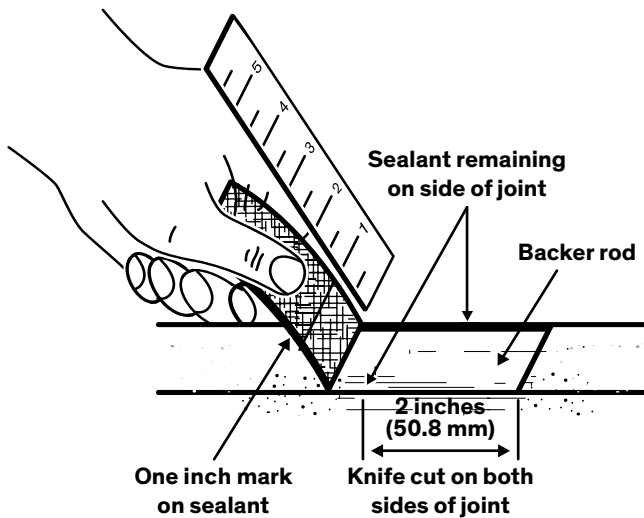

How to Use DOWSIL™ Silicone Pavement Sealants

Cure Characteristics

DOWSIL™ silicone pavement sealants cure by reacting with atmospheric moisture, but the rate of cure is dependent on temperature and humidity. The cure will be faster with higher temperatures and humidity and slower with lower temperatures and humidity.

At a temperature of 75°F (24°C) and relative humidity of 50 percent, DOWSIL™ 888 Silicone Joint Sealant will skin over in under an hour and reach its ultimate properties in 7 to 14 days. Higher temperatures will reduce the initial skin over time and performance property time. Conversely, low temperatures will increase the skin-over time and increase the total cure time.

At a temperature of 75°F (24°C) and a relative humidity of 50 percent, DOWSIL™ 890-SL Silicone Joint Sealant will skin over in under an hour. The self-leveling sealant will reach its ultimate properties in 14 to 21 days. Like DOWSIL™ 888 Silicone Joint Sealant, skin over and cure times will decrease with warmer temperatures and increase with colder temperatures.

While it may require several days for the sealant to reach ultimate properties, roads or airfield applications may be reopened to traffic once the sealant forms a skin, generally within an hour during warm weather.

Joint Design

Good sealant installation begins with good joint design, and anticipated movement is a key design consideration. While the high movement capability of DOWSIL™ silicone sealants provides added safety when anticipated and actual movements differ, proper design and correct installation procedures will maximize performance.

Joint Width

Joints may either be sawed or formed to the required dimensions. The minimum joint width recommended for DOWSIL™ silicone pavement sealants is 1/4 inch (6.35 mm).

Transverse joints must be wide enough to prevent excessive movement. A 1/4 inch (6.35 mm) wide joint with 20 foot (6 m) spacing may be satisfactory in a warm climate, but more severe climates with wide temperature ranges or less frequent spacing will require a wider joint. Joint spacing, the coefficient of thermal expansion of the pavement, expected temperature range, and the anticipated temperature at time of sealing must all be considered.

The pavement should be designed and joints sized so the maximum extension and compression do not exceed +100 and -50 percent respectively.



Figure 2 – Joint Design Considerations: DOWSIL™ 888 Silicone Joint Sealant

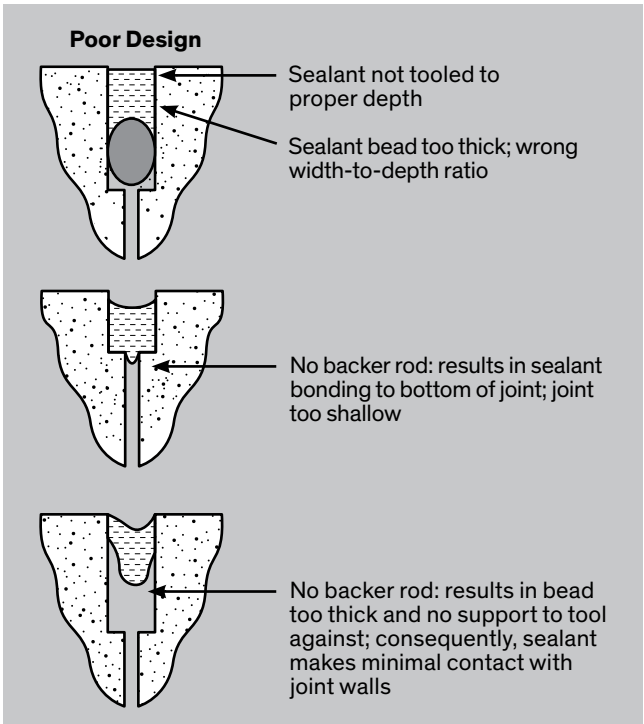
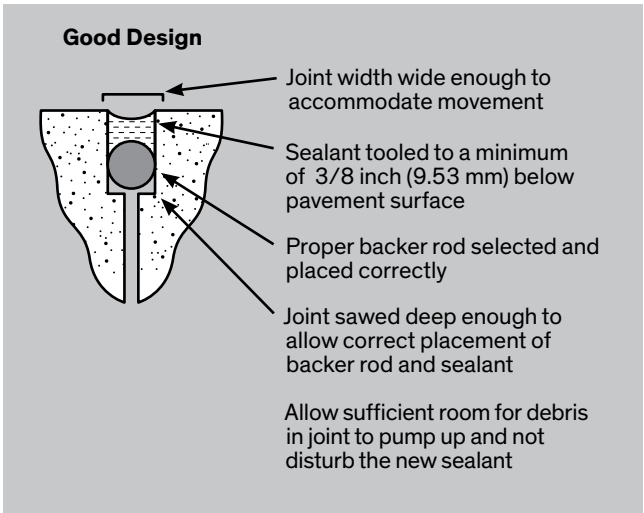
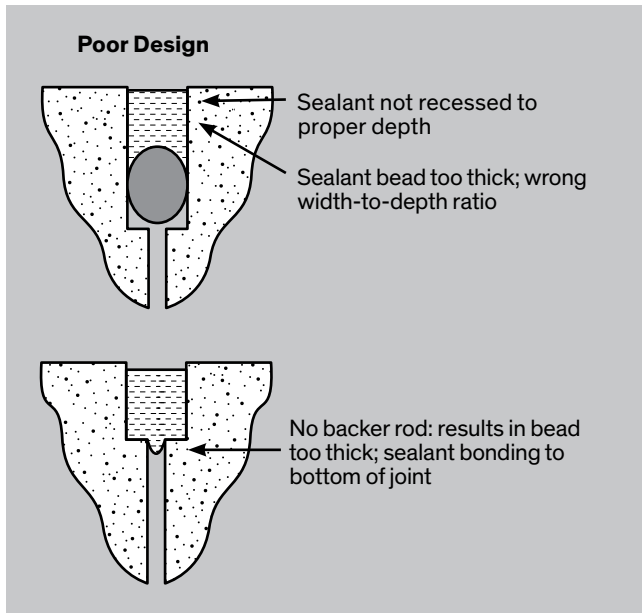
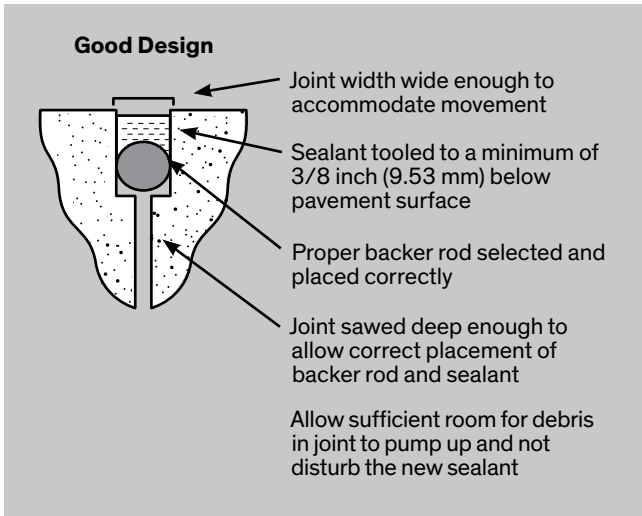

Figure 3 – Joint Design Considerations: DOWSIL™ 890-SL Silicone Joint Sealant



* Recess is measured from the highest point of the installed backer material to the lowest point of the pavement surface at the joint wall.

Joint Depth

The joint must be deep enough to allow proper placement of the sealant and a bond breaker/backer rod. Minimum depth requirements will vary slightly depending on joint width.

Table 1 – Recommended Joint Depth

Joint Width	Minimum Recess
1/4 to 1 inch (6.35 to 25.4 mm)	3/8 inch (9.53 mm)
> 1 inch (> 25.4 mm)	1/2 inch (12.7 mm)

Experience has shown that better performance of DOWSIL™ silicone pavement sealants can be obtained by maintaining a recess of 3/8 inch (9.53 mm) or greater. It is especially important to maintain the proper recess as the joint width approaches and/or exceeds 1 inch.

Joint Preparation

Obtaining the desired performance depends on using correct installation procedures. All contaminants, especially dried laitance from saw-cutting and previous sealants, must be removed with a high-pressure water wash followed by a sandblast after the joint dries. Leaving materials of this type on the surface of the joint face will prevent development of a good adhesive bond. A clean joint will have no visible signs of residual sealant or debris on the joint wall, and will leave no residual cement powder or dust on your fingers after rubbing the joint face.

DOWSIL™ 888 Silicone Joint Sealant will not bond to wet concrete. DOWSIL™ 890-SL Silicone Joint Sealant will not bond to wet asphalt or concrete. Moisture in and on the pavement is difficult to detect. The pavement must be allowed to dry. When in doubt, it is wiser to allow additional drying time than to risk sealant adhesion failure.

After drying, it is especially important to sandblast the top portion of the joint the sealant will contact. When sandblasting, follow all federal, state and local laws and regulations regarding the proper use and handling of equipment. The primary purpose is to remove traces of residual laitance. The sandblasting nozzle must be held at an angle to the joint face and within 1 or 2 inches (25.4 or 50.8 mm) of the pavement. Pointing it toward the bottom of the joint or at too great a distance from the face allows the force of the blast to dissipate resulting in ineffective cleaning. These points and others regarding surface preparation of new and old concrete pavement are expanded upon in following sections.

Backer Rod Selection

An essential element in good joint design is the use of a bond breaker or backer rod. A primary function of the backer rod is to act as a bond breaker, preventing three-sided adhesion of the sealant while at the same time forming the desired cross-section of the sealant bead. Failure to utilize a backer rod will allow the sealant to bond to the bottom of the joint, which may result in excessive stress on the sealant.

Another function of the backer rod is to control the thickness of the sealant bead. The backer rod should be approximately 25 percent oversized so that it fits tightly into the joint. A loose backer rod will be pushed deeper into the joint when the sealant is installed and will not provide adequate support for proper tooling of DOWSIL™ 888 Silicone Joint Sealant. Thus, the thickness of the sealant bead cannot be controlled as required. With proper tooling, DOWSIL™ 888 Silicone Joint Sealant is pushed down onto the backer rod and firmly against the joint walls, resulting in intimate contact, proper wetting and good adhesion with the joint walls. DOWSIL™ 890-SL Silicone Joint Sealant requires a tight fitting backer rod to control thickness of the sealant bead and to prevent the sealant from bypassing the backer rod to the bottom of the joint.

Failure to use a backer rod, or use of the wrong material, will likely result in reduced performance of the sealant. Dow recommends the use of a closed cell, expanded polyethylene foam rod for general use with DOWSIL™ silicone pavement sealants. Where the joints are irregular, backer rods with a skin that prevents water absorption help prevent the self-leveling sealants from bypassing the backer rod and allow the sealants to enter the bottom of the joint. In all cases, the backer rod must be oversized so that it fits tightly in the joint.

Sealant and Backer Rod Placement Depths

The sealant bead must be recessed a minimum of 3/8 inch (9.53 mm) below the pavement surface. The sealant bead should be a minimum of 1/4 inch (6.35 mm) thick but not greater than 1/2 inch. A width-to-depth ratio of 2:1 is suggested for joints less than one inch wide and should be maintained throughout the bead whenever possible. This ratio is not applicable for joints 1/4 inch wide or joints over 1 inch wide.

If other operations, such as diamond grinding, are to be performed after sealant installation, the sealant recess and the resulting joint depth and backer rod placement may need to be increased. Preferably, the sealant should be installed after surface grinding to avoid damage to the sealant.

Sealing New Concrete Pavement

Before attempting to seal joints in new concrete, the concrete must be given adequate time to cure, dry and develop strength so the joint reservoir can be sawed without concrete damage (e.g. raveling, spalling, etc.). The time between sawing of the initial cut (contraction cut to control cracking) and the joint sealant reservoir will depend on such factors as mix design (e.g. conventional, Fast Track, High Early Concrete mixes), cement type, time of year concrete is placed, temperature, etc. Only clean and dry joints should be sealed.

For conventional concrete mixes, it is recommended that the concrete be allowed to cure and dry a minimum of seven days in good drying weather before installing DOWSIL™ silicone pavement sealants. Cold, wet, inclement weather will require a longer drying time. An additional day of good drying weather should be allowed for each day of poor drying weather.

DOWSIL™ silicone pavement sealants have been successfully used in many Fast Track and High Early Concrete applications. Because of the continued introduction of new methods and mix types, please contact your Dow representative for current recommendations in these applications.

Joint sealant reservoirs are prepared by saw-cutting the concrete to the specified width and depth. It is recommended that freshly sawed joints be washed with high-pressure water immediately after sawing to remove most of the saw slurry from the joint faces. Joint washing should be in one direction (working forward) to minimize recontamination.

After the joints have dried, they should be sandblasted to remove residual laitance from the joint walls. Sandblasting should be done in two passes, one pass for each face, with the nozzle held at an angle to the joint face and within 1 or 2 inches (25.4 or 50.8 mm) of the pavement. Sandblasting should be done to the depth at which the sealant and backer rod are to be installed.

Experience has shown that the best method for removing contaminants is by sandblasting the dry joint that was previously flushed with water after the saw-cutting process. Other techniques, such as grinding or wire-brushing, are not recommended. They have been found to be less effective due to possible operator error and/or equipment problems. If conditions are such that sandblasting is not permitted, high-pressure waterblasting may be used as an alternative. Contact your Dow representative *before* attempting to use this joint cleaning method to discuss the appropriate procedures.

After sandblasting, the blasting media, as well as any dust and dirt deposited by wind and traffic, must be blown out of the joint and away from the area around it using a high-pressure air blast. As with the water wash, the air blast should move in only one direction (forward) to prevent recontamination of the joint. Compressed air, at a pressure of at least 90 psi (620 kPa), should be used to blow out the joint just before installation of the backer rod. Air compressors used for this purpose must be equipped with traps capable of providing moisture-free and oil-free air.

Just before the backer rod is installed into the joint, rub your finger across the dry joint face to determine that residual dust or dirt has been removed. If joints still contain dust or dirt, contaminants must be removed before backer rod and sealant installation.

Solvents should not be used to remove oils, because they generally only carry the materials further into the concrete pores or spread them over the surface. Solvents that have not completely flashed may also affect the sealant cure process.

Note: *Many new concrete additives are being sold to the highway industry that allow concrete to be placed and opened to traffic in less time. These materials may be additives to or substitutions for Portland Cement Concrete. When using any of these new materials, adhesion testing of DOWSIL™ silicone pavement sealants is suggested. To test adhesion, submit samples of the material to Dow at least 30 days before anticipated use. Dow will test the material and provide you with specific recommendations.*

Resealing Old Concrete Pavement

The installation techniques required for resealing can be summarized as removal of old sealant/seal, proper cleaning of the joint and installation of the bond breaker and sealant.

The tools and techniques used to remove the existing sealant or joint filler will be determined by the material in the joint and by available equipment. The old sealant can be removed by cutting or saw-cutting, which slightly widens the joint, to produce a new surface for sealing. Some materials, compression seals for example, are simply pulled out of the joint and then sandblasted to remove the lubricant/adhesive.

After removing previous materials, immediately high-pressure water wash the joint to remove sawing residue. Wash in one direction (forward) to prevent recontamination. When the joint has dried, it should be sandblasted to remove any residual dust using techniques described previously.

After sandblasting, the joint should be blown out with compressed air at a pressure of at least 90 psi (620 kPa) to remove blasting media and dust. Air should be free of oil and water.

As a final check before bond breaker and sealant installation, the joints should be inspected for residual dust and/or old sealing material. If dust or old sealing materials remain, contaminants should be removed using techniques described previously.



Table 2 – Theoretical Estimating Requirements*

Joint Width, inches	Sealant Bead Thickness, inches	Minimum Joint Depth, inches	Backer Rod Diameter, inches	Coverage, linear feet per gallon
1/4	1/4	1-1/8	3/8	309
3/8	1/4	1-3/8	1/2	205
1/2	1/4	1-3/8	5/8	154
5/8	5/16	1-5/8	3/4	99
3/4	3/8	1-7/8	1	69
7/8	7/16	2	1	51
1	1/2	2-1/8	1-1/4	39
> 1	1/2	> 2-1/8	≥ 1-1/4	

*Actual yield will vary depending on deviation from calculated bead shape, tooling techniques, backer material placement, waste, and applicator experience.

Table 3 – Metric Estimating Equivalents*

Joint Width, mm	Sealant Bead Thickness, mm	Minimum Joint Depth, mm	Backer Rod Diameter, mm	Coverage, linear meters per liter
6.35	6.35	28.6	15.9	26
9.35	6.35	34.9	15.9	17.6
12.7	6.35	34.9	15.9	13
15.9	7.94	41.3	17.5	8.3
19.1	9.53	47.6	19.1	5.5
22.2	11.1	50.8	20.6	4.2
25.4	12.7	54	22.2	3
> 25.4	12.7	> 54	25.4	

*Actual yield will vary depending on deviation from calculated bead shape, tooling techniques, backer material placement, waste, and applicator experience.

Full Depth Asphalt Pavements

Note: Only DOWSIL™ 890-SL Silicone Joint Sealant is recommended for sealing joints in asphalt pavements.

Sealing New Asphalt Pavements

Before attempting to seal joints in new asphalt, the asphalt must be given sufficient time to cool and to cure so damage will not result from sawing. This time will depend upon a number of factors, such as mix design, time of year for placement, geographic location and past experiences. The asphalt must also be completely dry prior to sealant installation.

Joints should be prepared by saw-cutting to the specified width and depth. Routers (i.e. impacting devices) should not be used, as routing of asphalt pavements can cause damage to the pavement, which in turn may lead to poor joint performance. In new construction, a shallow cut is recommended where the backer material is placed on the bottom of the joint. A shallow cut saves time and saw blades. All joints to be sealed must be sound, clean, dry and frost-free.

Freshly sawed joints should be washed with water immediately after sawing to remove any loose material from the joint faces. Wash the joint in a forward direction to prevent or minimize recontamination. Any contaminants remaining on the surface of the joint wall may prevent development of a good bond.

Experience has shown the best method for removing contaminants is by sandblasting the dry joint that was previously flushed with high-pressure water after the sawcutting process. Other techniques, such as grinding, wirebrushing or routing, have been found to be less effective and may cause damage to the joint.

Sandblasting should be done in two passes, one pass for each face, with the nozzle held at an angle to the joint face and within 1 or 2 inches (25.4 or 50.8 mm) of the pavement. Sandblasting should be done to the depth at which the sealant and backer material are to be installed. The blasting media, as well as dust and dirt deposited by wind and traffic, must be blown out of the joint and away from the area around it using a high-pressure air blast. The air blast should move in a forward direction.

Compressed air, at a pressure of at least 90 psi (620 kPa), should be used to blow out the joint just before installation of the backer rod. Air compressors used for this purpose must be equipped with traps capable of providing moisture-free and oil-free air. Just before actual sealing the joint, rub your finger across the dry joint face to determine that residual dust has been removed. If joints still contain dust or dirt, these contaminants must be removed before backer rod and sealant installation.

Resealing Old Asphalt Pavements

All old sealant and/or joint filler must be removed prior to sealant installation. The tools and techniques used to remove the existing sealant or joint filler will be determined by the material in the joint and by available equipment. The old sealant typically can be removed by cutting, plowing and/or saw-cutting, which also widens the joint to the required dimensions. Residue from sawing (i.e. wet sawing) of asphalt and any old caulk or sealant material still remaining on the joint face must be removed before backer rod placement and resealing. As discussed in previous sections, any debris and residue left by the wet sawing operation must be removed by an immediate high-pressure water wash. This is followed, after drying, by sandblasting using techniques described previously.

After sandblasting, the joint is blown out with compressed air to remove final dust and dirt from the previous step and any dust and dirt that may have been blown in by traffic, wind, etc. The compressed air is supplied from a compressor equipped with traps to provide oil-free and water-free air at a minimum of 90 psi (620 kPa).

As a final check prior to installing backer material and sealant, the joints should be checked to ensure that joints are dry and no residual dust remains. This is accomplished by rubbing your finger along the joint face to examine for dust. If dust is present, it must be removed before proceeding with backer material installation.

Asphalt Overlays

Note: Only DOWSIL™ 890-SL Silicone Joint Sealant is intended for sealing joints in asphalt pavements.

Sealing Joints in New Asphalt Overlays

It is recommended that joints in fresh asphalt be sawed after the asphalt has cooled and 'cured' so that sawing does not damage the asphalt joint (i.e. raveling). The joints should be centered *directly over* the concrete joints below. To control cracking, it is common practice to carefully saw these joints to a depth of 1/2 of the total asphalt thickness. Then the sealant reservoir should be sawed to proper dimensions. Joint dimensions should comply with state specifications.

As discussed previously, the joint must be free of moisture, sawing residues, dirt, dust, etc. prior to sealant installation. The removal techniques have been described in previous sections.

Sealing Concrete / Asphalt Shoulder Joints

Note: Only DOWSIL™ 890-SL Silicone Joint Sealant is intended for sealing joints in asphalt pavements.

When DOWSIL™ 890-SL Silicone Joint Sealant is used to seal concrete-to-asphalt shoulder joints, the asphalt should be completely removed from the concrete face to which the sealant will be bonding. This can be accomplished by saw-cutting tightly along the concrete. Failure to remove all the asphalt may result in joint failure. A fresh and sound joint face must also be prepared in the asphalt by saw-cutting. Saw-cut the asphalt a minimum of 1/4 inch (6.35 mm) beyond any raveled edges. If the concrete-to-asphalt shoulder has been sealed before, the previous sealant should be removed from both the concrete and asphalt faces. This is accomplished by saw-cutting.

As discussed previously, any debris left by the sawing operation must be removed by an immediate high-pressure water wash. This is followed, after drying, by sandblasting using techniques described previously.

Backer Material Installation

After the final cleaning, the backer material should be installed at the proper depth, as shown in Table 2. The depth is measured from the paved surface of the lowest slab (if faulting is present) to the top of the backer rod.

Backer rod may be installed by hand, but a roller device (Figure 4) to aid in placement can be easily constructed. This device will not only speed installation, but also ensures a consistent, uniformly placed backer at the proper depth.

For new construction that has deep tining, the backer material should be placed deeper so the sealant will be below tining and have the specified bead thickness.

In cases where the pavement is faulted or where future surface grinding is anticipated, the backer material (and sealant) may be installed deeper than normal so after grinding, the sealant is at the recommended recess. Ideally, grinding should be performed prior to backer material and sealant placement. If grinding is performed after sealant installation, any areas damaged by grinding should be repaired by removing and replacing sealant.

Figure 4 – Backer Rod Installation Tools

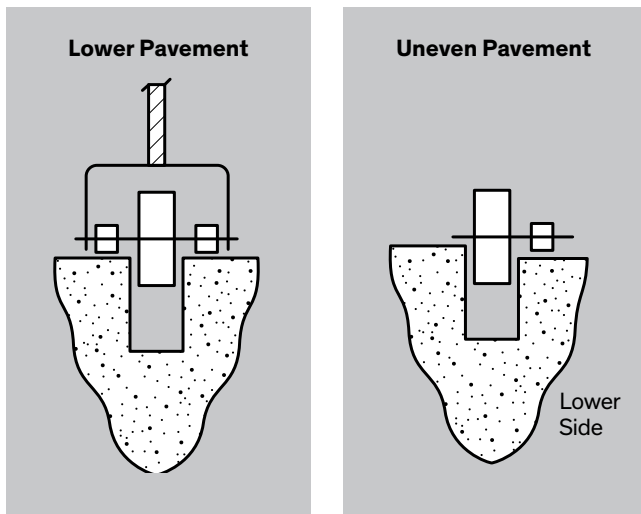

Sealant Installation

DOWSIL™ silicone pavement sealants should be pumped directly from the original drum or pail into the joint by use of an air-powered pump. The nozzle should be moved steadily along the joint to form a uniform sealant bead. With proper backer rod installation, the following applies:

- DOWSIL™ 888 Silicone Joint Sealant should fill the joint from the top of the backer rod to slightly below the pavement surface. Immediately after placement and before a skin forms, DOWSIL™ 888 Silicone Joint Sealant must be tooled so it is forced against the joint faces and the bead is recessed below the pavement surface as recommended by Dow. This tooling is required because the material is not self-leveling and must be forced against the joint faces to wet them and gain maximum adhesion.
- DOWSIL™ 890-SL Silicone Joint Sealant should fill the joint from the top of the backer rod and recessed below the pavement surface as recommended by Dow. Tooling is not required.

Preferably, sealants should be installed when the temperature is at 40°F (4°C) and rising. However, it has been installed at lower temperatures. Situations of this type require caution that the joint is clean, dry and frost-free. They should be discussed with representatives of the manufacturer before installation.

In new construction, where the concrete pavement is deeply tined, it is recommended that the sealant be placed below the tining grooves. Thus, if concrete chipping occurs at the joint face, a watertight seal will be maintained. Excess sealant on the pavement surface should be scraped up and removed to prevent possible tracking.

When the specifications call for non-silicone sealants, especially asphalt-based materials in the longitudinal joints and silicone in the transverse, the silicone sealant should always be installed first in order to prevent contamination of the joint faces. Preferably, the silicone will also be installed in the longitudinal joint a foot (305 mm) or so in both directions from the transverse joint. This should reduce the possibility of a weak point at the intersection of transverse and longitudinal joints.

Many devices for injecting and tooling the sealant are shop-fabricated. The specific device selected depends largely upon the applicator's personal preference. For assistance, please contact your Dow representative.

For DOWSIL™ 888 Silicone Joint Sealant, success has been achieved with flexible spatulas and backer rods of larger diameter than the joint width. Flexible devices seem to offer better results, because they are able to form the sealant to the contours of the pavement.



Installation Equipment

Equipment needed to install DOWSIL™ silicone pavement sealants can be operated manually or with power. Powered equipment is recommended because of the speed and ease of application. Manually operated equipment can be successfully used for small applications. Cartridges (29 ounce [858mL]) are available for activities of this type. Air-powered versions of the small, hand-held caulking guns are also available.

The major pieces of power equipment required to install DOWSIL™ silicone pavement sealants are an extrusion pump (Figure 5) to transfer the material from the container to the joint and an air compressor capable of delivering air at 60 CFM (28.3 L/s) and 100 psi (690 kPa). Complete units including air-powered pump, follower plate and hose are required for both pails and drums. For versatility, the same unit can be used for both drums and pails, provided the system offers interchangeable follower plates.

Figure 5 – Extrusion Pump

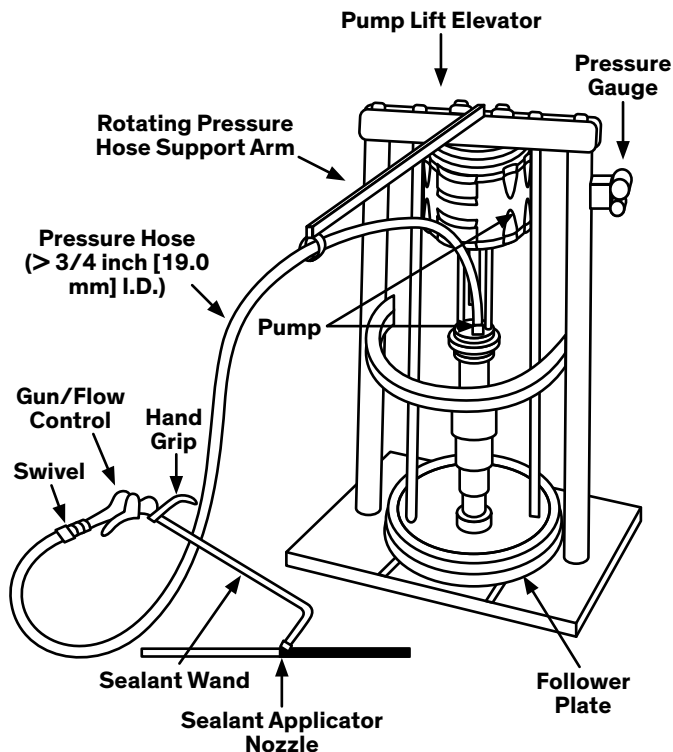

Air-powered equipment is available with varying output capacities. The ratio of the extrusion pump and accessory components of the system, especially hose diameter, will determine output volume. Specific ratios vary among manufacturers, but a ratio of 35:1 is the minimum capable of delivering a sufficient volume of sealant for efficient operation. Selection of the pump and accessory equipment should be based on desired production rates.

A partial list of manufacturers of this equipment is shown in Table 4. They should be contacted for specific recommendations. Please contact manufacturers directly for most current pump equipment information. This is not intended to be a complete list of pump manufacturers.

Table 4 – Manufacturers of Power Installation Equipment

Ingersoll-Rand Industrial Technologies ARO Fluid Products One Aro Center Bryan, OH 43506 +1 800 495 0276 www.arozone.com	Graco, Inc. 88-11th Ave. N.E. Minneapolis, MN 55413 +1 800 328 0211 www.graco.com
---	---

Regardless of which manufacturer's system is chosen, several common equipment features will be required. DOWSIL™ silicone pavement sealants cure on exposure to atmospheric moisture, so seals and hoses should be selected that will prevent or minimize moisture permeation.

Hoses and hose connections must not only prevent moisture permeation, but must also be able to withstand pumping pressures and be tough enough to resist abrasion on the job site. Hoses lined with Teflon are recommended because their low air and moisture permeability will provide long, trouble-free service. Other hoses, such as the BUNA-N hose, have also been found to provide satisfactory performance over an entire construction season. Nylon-lined hoses are not recommended.

Most unlined hoses allow the sealant to cure in the hose and block flow. This blockage may take several weeks to several months to form but, in extreme cases may take just one to two days, depending on the hose material,

wall thickness and temperature and humidity conditions. Regular cleaning of hoses of this type will be necessary.

All seals and packings should be made of Teflon. The more common neoprene, urethane and leather seals are not satisfactory, because they do not prevent moisture permeation.

Hose runs should be kept to a minimum and reasonable length to reduce pressure drops. A hose I.D. (inside diameter) of at least 3/4 inch (19.0 mm) is recommended. When longer hose runs are needed, it is suggested that a larger diameter hose (1 to 2 inches [25.4 to 50.8 mm]) be coupled with a smaller, 3/4-inch (19.0 mm) whip hose near the wand to minimize the overall pressure drop.

Daily cleanup is not needed. However, the sealant nozzle should be sealed to prevent curing. When the equipment and hoses will not be used on a regular basis, they should be cleaned by flushing the entire system with a solvent. Mineral spirits has proven to effectively clean uncured silicone. Follow manufacturer's instructions for use and handling and conform to all local, state and federal regulations. Proper eye protection should be worn. On startup, care must be taken that these materials are completely flushed from the pump and hoses.

Do not use grease to purge or clean the pump.

Manual Installation Equipment

Manually operated equipment is available from various manufacturers and can be obtained from local supply houses. Many Dow distributors stock this equipment. You can obtain their contact information from Dow.

Specification Information

Please contact your local Dow representative for product specification information.



Figure 6 – Installation



Water-washing the Joint



Sandblasting the Joint



Air-blasting the Joint



Installing the Backer Rod



Installing DOWSIL™ 890-SL Silicone Joint Sealant



Field Adhesion Test

Questions and Answers

Q: What different kinds of equipment are needed to install DOWSIL™ 888 Silicone Joint Sealant?

A: Basic equipment needed is 1) an air-powered dispensing pump and 2) a conventional air compressor. The product does not require heating, so expensive heating kettles are not needed. It also requires no mixing.

Q: Can both DOWSIL™ silicone pavement sealants be installed with the same equipment?

A: Yes, both sealants are compatible, and no special equipment is needed to install the self-leveling sealant. However, care should be exercised to ensure that only DOWSIL™ 890-SL Silicone Joint Sealant is used on asphalt.

Q: Can the same equipment be used to install DOWSIL™ silicone pavement sealants and other silicone sealants?

A: Due to possible differences in the sealant chemistry, cross-contamination could cause cure inhibition. If other silicones are used, the equipment must be thoroughly flushed with an aromatic solvent, such as mineral spirits, prior to using DOWSIL™ silicone pavement sealants.

Q: What is the minimum joint width that can be sealed?

A: Minimum joint width should be 1/4 inch, though a 3/8 inch (9.53 mm) wide joint will likely make cleaning and sealant installation easier.

Q: What is the maximum joint width that can be sealed?

A: It is recommended that joints to be sealed should be no more than 2 inches (50.8 mm) wide. A Dow representative should be consulted on a case-by-case basis for sealing joints wider than 2 inches (50.8 mm). In the case of repair of asphalt, the joints must be widened enough so that all existing cracks are removed. The asphalt to be sealed must be sound.

Q: How long after resealing can the road be opened to traffic?

A: Generally, the road may be reopened in approximately one hour. This allows the sealant to skin over,

minimizing the possibility of dirt and stones penetrating the wet sealant. More time may be necessary depending on local conditions or specification requirements.

Q: Why must DOWSIL™ 888 Silicone Joint Sealant be tooled?

A: DOWSIL™ 888 Silicone Joint Sealant is not a flowable or self-leveling sealant. Therefore, it must be tooled to ensure intimate contact with the substrate.

Q: Why does Dow recommend that all silicones be recessed below the road surface?

A: By recessing the silicone sealant at least 3/8 inch (9.53 mm) below the road surface, the contact between vehicle tires and sealant is eliminated. Since silicones are not abrasion-resistant, vehicle tire contact should be eliminated. Depending on joint movement, a recess greater than 3/8 inch (9.38 mm) may be necessary.

Q: What is the most effective way to seal concrete joints where an edge has been chipped off?

A: Assuming the chipped area is small, the sealant should be installed so it is recessed below the lowest point of the chipped area and does not come in contact with traffic.

Silicone sealants are not designed to be concrete patching materials. When the chips or spalls become large, joints should be repaired prior to sealing.

Q: What federal or ASTM specifications do DOWSIL™ silicone joint sealants meet?

A: DOWSIL™ silicone pavement sealants are tested to several ASTM test methods. Listed below are a few frequently requested test methods and specifications.

- ASTM D5893
- ASTM C719 (+100%/-50%)
- ASTM 793 (5,000 hours)

Please refer to the Dow data sheet for a specific product, or contact your local Dow representative for additional test information.

Q: Are DOWSIL™ silicone joint sealants resistant to jet fuels?

A: Independent evaluations, Dow internal testing and field tests have shown silicone pavement sealants will not

degrade with short-term exposure to jet fuel. Dow has created a literature piece explaining the jet fuel resistance characteristics of DOWSIL™ silicone pavement sealants (Form No. 62-207). Additionally, airfield case histories of our products are available upon request. Contact your Dow representative for additional information.

Q: Can DOWSIL™ 888 Silicone Joint Sealant be used in asphalt pavement or with asphalt shoulders?

A: Dow does not recommend use of this product in this type of situation. However, DOWSIL™ 890-SL Silicone Joint Sealant is an ultra-low-modulus sealant designed to exert minimal force on the substrate to which it is adhered, so it provides excellent performance where asphalt pavement is involved.

Q: Can a torch be used to dry previously used wet joints?

A: This technique is not recommended for two reasons. First, the torch will draw water from the bottom of the joint and give the substrate the appearance of being dry at the surface even though it is not dry throughout. Second, the carbon by-products of burning will be deposited on the joint surface, and these deposits will prevent or minimize adhesion.

Q: Do silicones require more cleaning than other materials?

A: Silicone sealants do *not* require more cleaning than other materials. Good preparation techniques are a fundamental requirement for all applications that rely on the formation of an adhesive bond. Improper cleaning prevents or minimizes the contact between the substrate and the sealant, thus minimizing the life expectancy of the product.

Q: Are all silicones alike?

A: All silicones are *not* alike. All true silicones have certain inherent properties, such as weather and UV resistance and high- or low-temperature performance capabilities. Aside from these similarities, there are product differences that allow one silicone sealant to out-perform another silicone sold for the same application. Because of Dow's leadership in the field of silicone technology, we offer the best available product for pavement sealing requirements of all kinds.

Q: When sealing asphalt, why is an ultra-low-modulus sealant, such as DOWSIL™ 890-SL Silicone Joint Sealant, necessary?

A: When sealing to asphalt, the tensile strength of the sealant at its maximum rated extension should be less than the tensile strength of the asphalt, otherwise the asphalt may fail cohesively due to the strain the sealant places on the asphalt. DOWSIL™ 890-SL Silicone Joint Sealant typically meets this requirement. Confirming the asphalt on a particular job has sufficient tensile strength for the sealant proposed for use is recommended.

Key Word Index

Asphalt Pavements.....	4, 20-22, 34
Backer Materials	4, 8, 12-16, 20-23
Concrete Pavements	4-5, 13-15, 18, 25
Cure Time	4-6, 8-9, 15-17, 20, 22, 28
Inclement Weather	7-8, 16
Installation Equipment	4, 26-29, 32
Installation Temperature.....	4-5, 8-10, 15, 25, 28, 34
Joint Cleaning.....	8, 14, 16, 18, 23, 28, 32, 34
Joint Moisture Effects.....	4-5, 7, 13, 17, 21, 28
Joint Preparation	7, 13-14, 34
Sample Specifications	17
Sealant Movement Capability	4-5, 9, 32
Sealant Tooling	5, 14, 19, 21 24-25, 33



For more information on these products, please refer to the Dow technical data sheets and installation guides, or visit our website at consumer.dow.com/construction.

Your local distributor is:

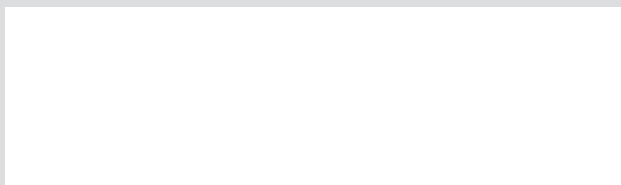

DOWSIL™

silicones by 

Image: dow_40609984508, dow_40264428445, dow_40264429465, dow_40609983329, dow_40609983665, dow_40609984469

HANDLING PRECAUTIONS

PRODUCT SAFETY INFORMATION REQUIRED FOR SAFE USE IS NOT INCLUDED IN THIS DOCUMENT. BEFORE HANDLING, READ PRODUCT AND SAFETY DATA SHEETS AND CONTAINER LABELS FOR SAFE USE, PHYSICAL AND HEALTH HAZARD INFORMATION. THE SAFETY DATA SHEET IS AVAILABLE ON THE DOW WEBSITE AT WWW.CONSUMER.DOW.COM, OR FROM YOUR DOW SALES APPLICATION ENGINEER, OR DISTRIBUTOR, OR BY CALLING DOW CUSTOMER SERVICE.

LIMITED WARRANTY INFORMATION – PLEASE READ CAREFULLY

The information contained herein is offered in good faith and is believed to be accurate. However, because conditions and methods of use of our products are beyond our control, this information should not be used in substitution for customer's tests to ensure that our products are safe, effective and fully satisfactory for the intended end use. Suggestions of use shall not be taken as inducements to infringe any patent.

Dow's sole warranty is that our products will meet the sales specifications in effect at the time of shipment.

Your exclusive remedy for breach of such warranty is limited to refund of purchase price or replacement of any product shown to be other than as warranted.

TO THE FULLEST EXTENT PERMITTED BY APPLICABLE LAW, DOW SPECIFICALLY DISCLAIMS ANY OTHER EXPRESS OR IMPLIED WARRANTY OF FITNESS FOR A PARTICULAR PURPOSE OR MERCHANTABILITY.

DOW DISCLAIMS LIABILITY FOR ANY INCIDENTAL OR CONSEQUENTIAL DAMAGES.

®™ The DOW Diamond and DOWSIL are trademarks of The Dow Chemical Company
Teflon is a registered trademark of E.I. DuPont de Nemours and Company.

© 2018 The Dow Chemical Company. All rights reserved.

30023848

Form No. 61-507-01 P